

The Series 300 Pressure Switches offer accurate, reliable switching in a robust cast enclosure.

Exd, ExnC, Exia, I.S.:

The certifications available on this range of switches enables them to be used in most hazardous area applications.

COMPACT DESIGN:

Having a width of only 70mm these switches are ideally suited for applications where space may be limited. The design allows for any number of these switches to be mounted in a row whilst still providing easy access to the electrical entry at the top of the switch and the process connection at the bottom.

COMPREHENSIVE RANGE:

The Series 300 includes switches for monitoring both pressure and vacuum. The ranges available from -1 to 600 Bar cover all medium to high pressure industrial applications. With a choice of aluminium or stainless steel IP66 housings these switches are equally well suited for mounting on-site or use in panels.

WIDE RANGE OF OUTPUT SWITCHES:

The wide range of electrical output switches available includes gold contacts for low current d.c. and silver contacts for high current a.c. Switching differentials are typically below 2% of the range.

A single pole double-throw microswitch (SPDT) can make or break a circuit at the required switching point. Dual switches (2 x SPDT) can make or break two independent circuits at the same or different switching points.

HIGH OVERLOAD RATINGS:

All Series 300 pressure switches use a diaphragm to monitor the process pressure. This type of switch can provide high pressure overload capabilities and is ideal for applications where the maximum process pressure can be much greater than the required switching pressure.

SIMPLE MAINTENANCE:

These switches can provide many years of maintenance free operation. However should the need arise output switch kits and diaphragm kits allow on-site repair rather than replacement to minimise the overall cost of ownership.

PROVEN PERFORMANCE:

Series 300 pressure switches have a long established reputation for providing good value without compromising accuracy and reliability.

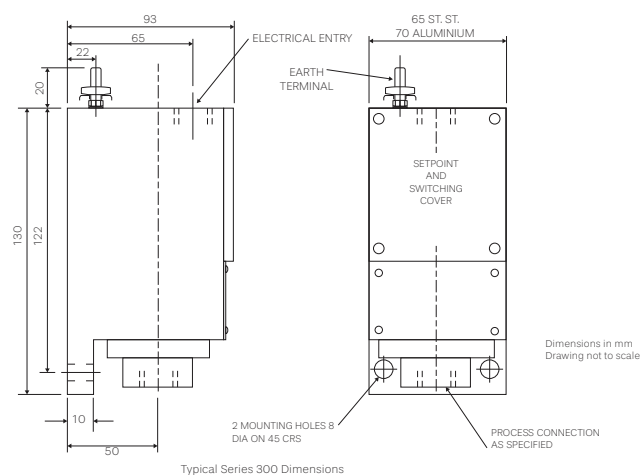

Series 300 Pressure Switch

Series 300 Pressure Switches Specifications & Coding:

Set Point Ranges (bar)				Diaphragm Material			Chamber Proof Rating (bar)		
Range Code	MIN	MAX	% RESET	Nitrile Code 1	PTFE Code 2	Hastelloy C Code 7	Anodised Aluminium Code 1	316 Stainless Steel Code 5	Hastelloy C Code 7
344 PZ	-0.6	0.6	2	✓	✓	✓	30	30	●
345 PZ	-1	1.4		✓	✓	✓	30	30	●
346 PZ	-1	6.0		✓	✓	✓	30	30	●
344 P	0.1	1.4	2	✓	✓	✓	30	30	30
345 P	0.2	3.0		✓	✓	✓	30	30	30
346 P	0.7	7.0		✓	✓	✓	30	30	30
348 P	1	10		✓	✓	✓	30	30	30
347 P	2	21	3	✓	✓	✓	35	35	35
354 P	1.2	12		*	✓	✓	*	250	250
355 P	3	30		*	✓	✓	*	250	250
356 P	7	70		*	✓	✓	*	250	250
357 P	20	210		*	✓	✓	*	350	350
358 P	60	600		*	✓	✓	*	1000	1000
Differential Pressure Ranges									
344 DPZ	-0.9	0.9	3	✓	✓	✓	30	30	30
345 DPZ	-1	2		✓	✓	✓	30	30	30
344 DP	0.2	2	2.5	✓	✓	✓	30	30	30
345 DP	0.4	4		✓	✓	✓	30	30	30
346 DP	1	10		✓	✓	✓	30	30	30
347 DP	2	21		✓	✓	✓	35	35	35
Key to options: ✓ = available * = not available ● = check availability with Rototherm Sales									

Note on Vent Ring Option:

As an additional safety feature, all of the Series 300 pressureswitches can be specified to include an optional vent ring. Its purpose is to isolate the electrical housing from the process in the event of process diaphragm failure, as shown.

If a vent ring is included a new process diaphragm can be fitted to allow the switch to be returned to service. Without a vent ring ingress of the process into the electrical housing may additionally necessitate the replacement of the output switch or render the switch unserviceable.

Inclusion of a vent ring will increase the overall length of the switch by 15mm.

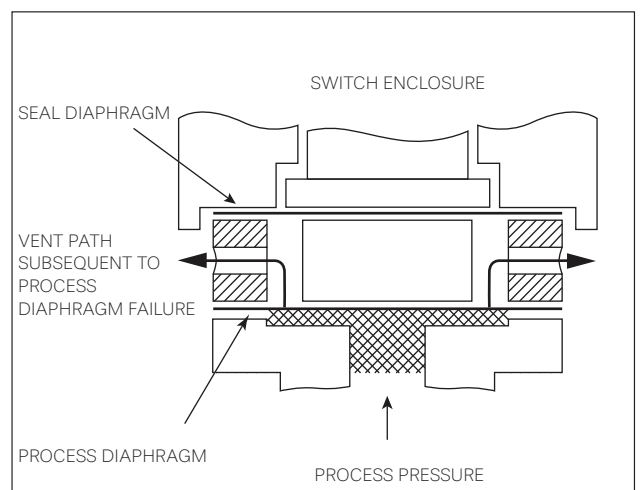

Output Switch (2nd digit)

Output Switch Codes			Availability of Output Switch Codes by Area Classification		
Single Switch	Output Switch Rating	Contact Material	Notes	B	4, 6, 7
3	250 Vac 4A, 28 Vdc 2A	Silver	Rototherm standard low differential microswitches	-	✓
4	125 Vac 800mA, 28 Vdc 800mA	Gold		-	✓
5	125 Vac 800mA, 28 Vdc 800mA	Gold	Environment free encapsulated low differential microswitch	✓	✓
7	250 Vac 4A, 28 Vdc 2A	Silver	Environment free encapsulated low differential microswitch	✓	✓
A	250 Vac 6A, 28 Vdc 2.5A	Silver	Rototherm standard encapsulated microswitches	-	✓
B	250 Vac 100mA, 28 Vdc 100mA	Gold		-	✓

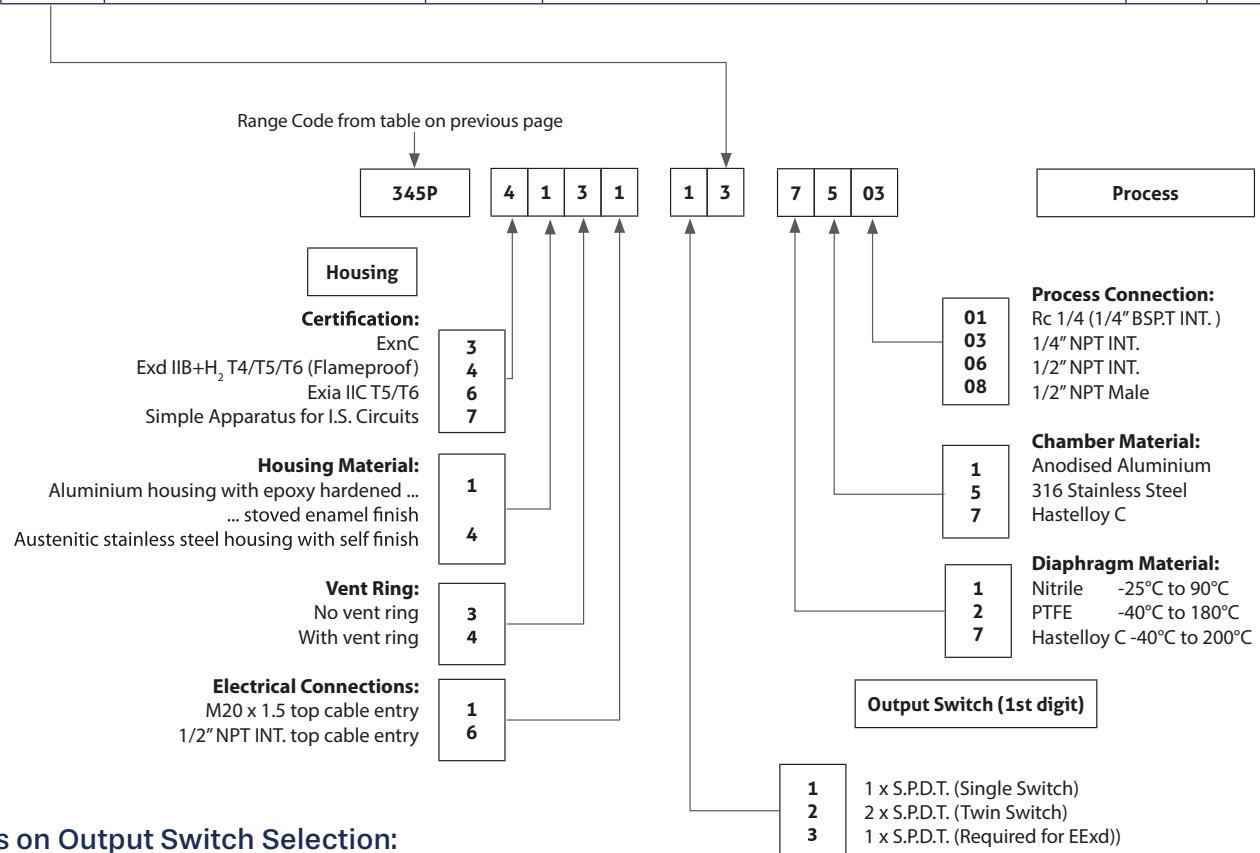

Notes on Output Switch Selection:

- Gold contact microswitches are especially well suited for low voltages and currents, or for applications with low switching frequencies or sulphurous atmospheres. When heavier loads need to be switched preference should usually be given to silver contacts.
- The use of twin switches will increase the basic reset by 1%. The combined reset band must not exceed 7%.
- When twin switches are set up to operate as DPDT, simultaneous operation on both rising and falling pressures cannot be guaranteed due to mechanical variations between individual microswitches.
- The use of output switch codes 1A, 2A, 1B and 2B will increase the basic reset by 1%.

Notes:

- Dust and weatherproof ratings are IP66 to BS EN 60529 (IEC 60529).
- A 'Z' within the range code signifies at or below zero. This is achieved with the use of a stainless steel biasing assembly within the process chamber. If stainless steel is not compatible with the process an alternative 'X' option is available (e.g. 344PX instead of 344PZ).
- A large number of alternative threaded connections, diaphragm & chamber materials are available as special options. Please contact Rotherm Technical Sales for details.

Series 300 Pressure Switch

Combined Switching Errors & Maximum Working Pressure (MWP):

In accordance with BS6134 1991:

The sum of the average switching errors and the operating value repeatability will typically not exceed 0.3% of range span, at setpoints of 10%, 50% and 90% of span, at constant calibration and measurement temperatures.

The maximum working pressure of the Series 300 switches is 0.67 x the proof pressure. It should be noted that diaphragm type switches generally have a high overload capability.

Reset (Switching Differential):

The reset varies throughout the range, normally increasing with setpoint, and the figure quoted in the range table is the switching differential value (as defined in BS6134) expressed as a percentage of the span at the mid range setpoint.

Ambient Temperature Ratings:

Enclosures are rated for continuous use over the temperature range -20°C to $+85^{\circ}\text{C}$. The use of a high T class will reduce the maximum ambient temperature. At T6 the maximum ambient temperature is 40°C for Exd, 65°C for ExnC and 75°C for Exia.

Storage limits for all enclosures are -50°C to $+90^{\circ}\text{C}$.

Exposure of the enclosure to direct sunlight should be such that the heat gain due to absorption of radiant energy does not cause the enclosure temperature to exceed the recommended maximum. Sufficient signal line cooling must always be provided to ensure that heat conduction from the process will not cause the switch enclosure to operate outside the stated ambient temperature limits.

Temperature Coefficient:

The additional error, relative to a setpoint calibration of 20°C , will not exceed 0.3% per 10°C change within the normal ambient temperature range of the switch enclosure.

Process Options:

For switches fitted with metallic diaphragms, a PTFE ring is incorporated on some ranges to provide additional sealing. Should PTFE not be compatible with the process media please contact Rototherm Technical Sales for advice on alternatives.

Standards:

This product satisfies the requirements of the Low Voltage Directive 73/23/EEC as amended by directive 93/68/EEC by compliance with standards EN60947-1:1991 and EN60947-5-1:2004.

This product complies with the following standards for hazardous area certification:-

Exd SWITCHES (Cert. No: Baseefa07ATEX0090X) Enclosures are certified Exd IIB+H2 T4/T5/T6 to EN 60079-0 & EN60079-1.

ExnC SWITCHES (Cert. No: HNL07ATEX0001X) Enclosures are certified ExnC IIC T4/T5/T6 IP66 100°C to EN60079-0, EN 60079-15.

Exia SWITCHES (Cert. No: Baseefa06ATEX0231X) Enclosures are certified Exia IIC T5/T6 to EN 60079-0 & EN 50020.

I.S. COMPATIBLE

Series 300 switches are classified as simple apparatus, allowing use in an I.S. circuit without individual certification.

Specifications

Parameter definitions are in accordance with BS6134:1991 (Pressure and Vacuum Switches).

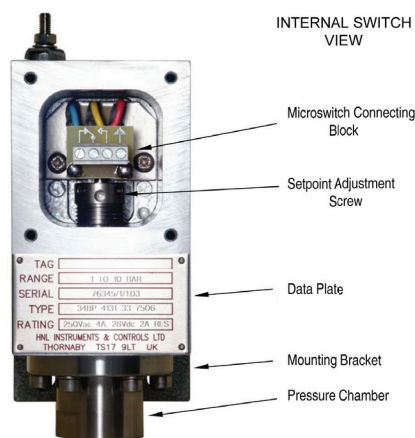

ISO9001:2015