

A Non-Invasive, Ultrasonic instrument with exceptional accuracy and reliability, providing Inventory Control of Pressurized vessels.

FEATURES:

- Certified for use in hazardous areas (ATEX, IECEx, UKEX)
- Can measure liquid levels up to 5 metres*
- TFT LCD Colour Display
- Non-invasive, Ultrasonic Technology
- Design for commercial applications
- Simple/Fast to install
- Displays: Temperature, Liquid Level (when combined with Multigauge on LPG tanks will display Pressure, Mass & Density)
- Transducers fitted with M12 industrial circular connector
- Seamlessly integrates with our in-house designed Portal via RotoHub (telemetry device)

* A greater level may be measured depending on product and tank type

BENEFITS:

- Better control of your inventory, as our RotoLevel;
 - > Measures liquid level & temperature within 0.5% accuracy
 - > When integrated with our pressure device, calculates density and mass on LPG tanks
 - > Transfers all information through to our telemetry device (RotoHub) to provide real-time analysis of your tank via our secure online data portal
- System uses ultrasonic technology resulting in;
 - > No tank break-in required, allowing for no downtime during installation (transducers fit outside of tank wall)
 - > Low maintenance
- Software and firmware updates can be performed Over The Air (OTA)
- Remote support (quick resolution without site visit needed)



Parameters Measured:

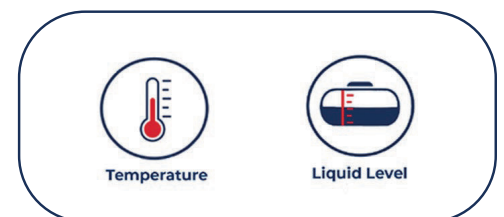

MEASUREMENT PRINCIPLES:

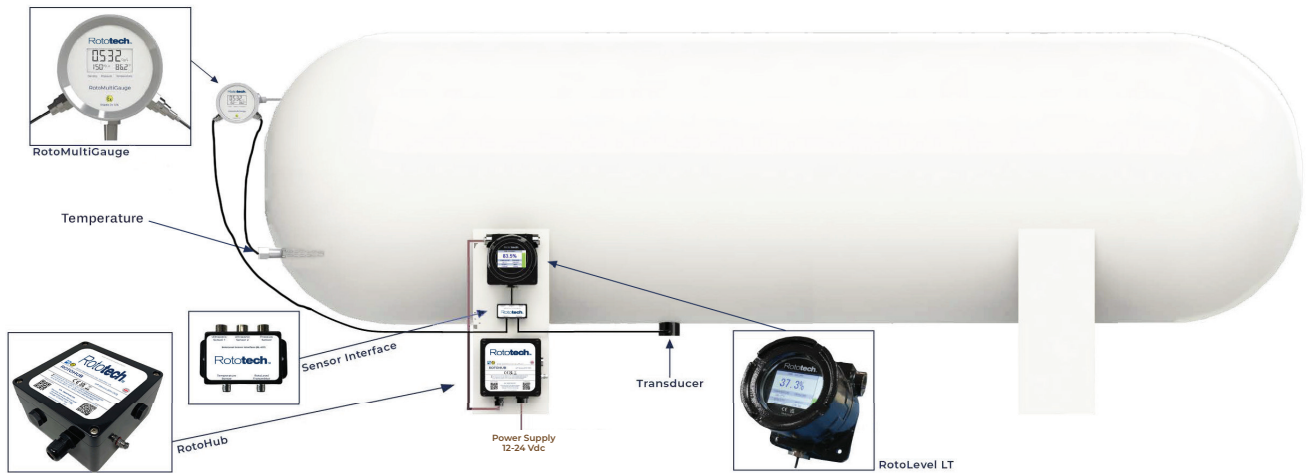

The RotoLevel LT uses Ultrasonic Technology and temperature sensors to determine accurate & reliable measurements. The sensor is connected to the base of the tank and emits a sound wave which travels through the tank medium and reflects back from the liquid surface.

The time of flight from emission to receiving the signal, together with temperature compensation and density of the liquid, is then processed and calculated by the system to determine the height of the liquid.

Each device is calibrated in our in-house laboratory using equipment traceable to UKAS/NIST standards.

The RotoLevel is connected to our telemetry device, (RotoHub) which then allows for duplex communications:

- 1 - Data is sent to our secure online portal for inventory control analytics accessible via any computer/tablet/mobile.
- 2 - Firmware/software updates can be automatically made to the devices at any time, always ensuring latest version.
- 3 - Our support team can remotely access the RotoLevel system to diagnose or resolve any issues that may arise.

ROTOLEVEL LT DIMENSIONS:

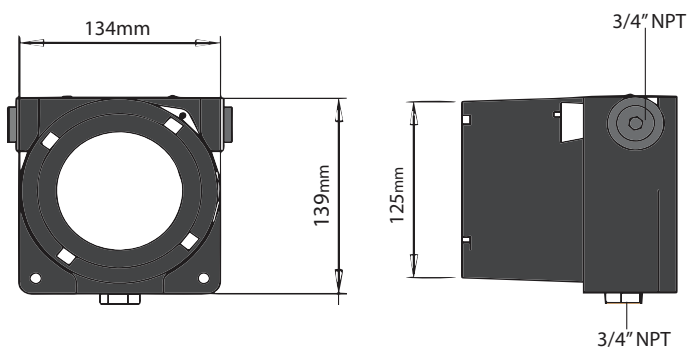

TRANSDUCER DIMENSIONS:

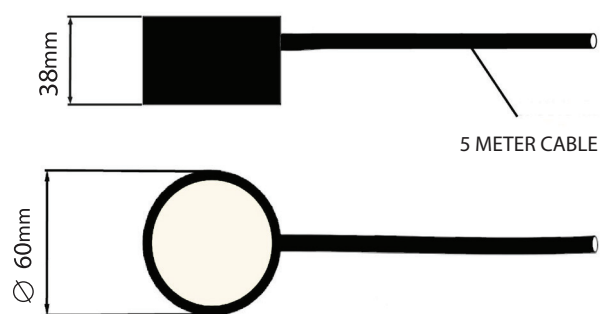

TRANSDUCER TECHNOLOGY:

RotoTechnology is part of the British Rototherm Group, a company with heritage dating back to the 1840's, who now design and manufacture reliable precision instrumentation for measuring pressure, temperature, level, density and flow. Here at RotoTechnology, we have applied the same precision and reliability into developing our own telemetry system and data analytics portal.

The first transducer was designed and installed in 1990 and RotoTechnology has since fine tuned the reliability and performance to become the global leader of non-invasive level transducer in the market. Our transducers are IS (Intrinsically Safe) certified and have a M12 IP 67 industrial circular connector to attach to the housing. This allows for rapid/easy installation of the transducer.

We utilise a magnetic housing that sits around the transducer and enables a very rapid and easy installation on ferromagnetic tanks. For non-ferromagnetic tanks, the transducer is bonded to the tank wall.



APPLICATION AREA:

Acids/Chemicals

- 98% sulfuric acid
- Acetaldehyde
- Acetone
- Butadiene
- Chlorine
- Chloroform
- Hydrofluoric acid
- Hydrogen fluoride
- Hydroxy nickel
- Liquid ammonia
- Liquid chlorine
- Naphtha
- Silicon tetrachloride
- Sulfuretted hydrogen
- Sulphur Dioxide

Hazardous

- Methyl alcohol
- Methylbenzen
- Solvents

LPG

- Butane
- Butene
- Propane
- Propene
- Ethane

Oil & Gas/Fuels

- Diesel
- Gasoline
- Petroleum



Horizontal Tank



Vertical Tank

TECHNICAL SPECIFICATION:

Accuracy	up to 0.5%
Level Range	5 meters *
Temperature Range (Transducer)	-20 °C to 60°C -4 °F to 140 °F
Temperature Range (RotoLevelLT)	-20 °C to 60°C -4 °F to 140 °F
Hazardous Area Approval (RotoLevel LT)	Ex II 2 (1) G Ex db [Ex ia] IIC T4 Gb Ta= -20°C ≤Ta ≤(+60°C)
Hazardous Area Approval (Transducer)	Ex II 1 G Ex ia IIC T4 Gb Ta= -20°C ≤Ta ≤(+60°C)
Transducer Material	Acetal
Transducer Attachment	Magnetic or Bonded
Transducer Weight	0.5kg
Serial Communications	RS485 Modbus RTU
Bluetooth® Connection	LTE
Analogue Output	0.5Vdc / 4.20mA (active)
Protection Rating	IP66
Software Operating System	Windows® 10
Power Supply	12 to 24Vdc
RotoLevel LT Weight	2.5kg
Size	Go to housing dimensions page 2

* A greater level may be measured depending on product and tank type
 - Any trademarks and trade names in this document are those of their respective owners

ORDERING CODE:

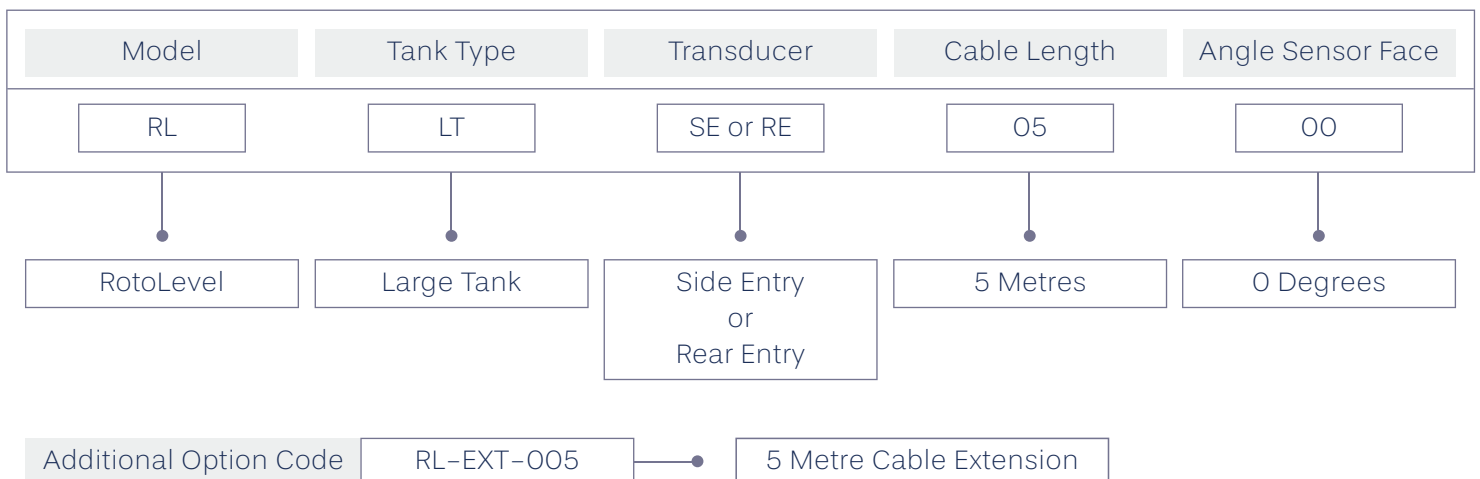

ONLINE DATA PORTAL:

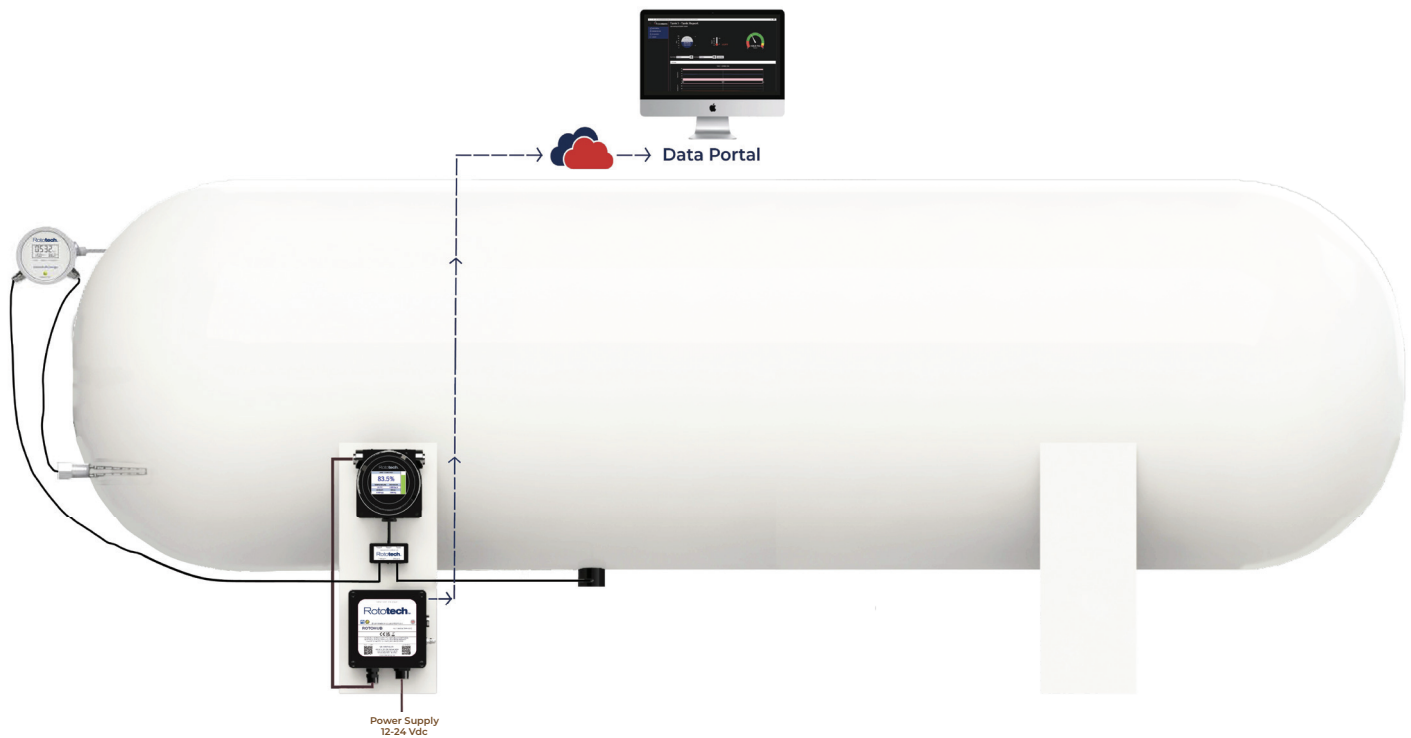

The **RotoLevel LT** is seamlessly connected to our secure Online Data Portal via our ATEX/IECEX certified telemetry device (**RotoHub**). Each RotoHub can accommodate up to a maximum of 4 RotoLevel LT devices and these are included and sold as part of our RotoLevel LT system.

Connecting the RotoLevel LT to our RotoHub allows for the following;

1. Remote Support

Our engineers are able to view the system 24/7 to resolve issues and/or provide automatic software or firmware updates.

2. Data Analytics

Our easy to use, secure online portal allows the user to monitor and control their tank inventory. Data is transmitted every 15 minutes ensuring real-time monitoring of level and temperature. The portal has ability to view historical data and set up various alarms for managing min/max limits.

3. Full Inventory Control

When connected with our pressure transmitter (**RotoMultiGauge**) we are able to provide pressure, density and mass analysis in real-time on LPG Tanks.

SENSOR INTERFACE:

Sensor Interface Device – when a reference sensor and/or pressure sensor is required.

For applications where pressure is also required to be measured, such as in LPG, our Digital Pressure Gauge will integrate seamlessly with the RotoLevel LT. In this instance, our Sensor Interface Device (RL-017) will also be required. Please see our Digital Multi Gauge datasheet for more details.

The interface device allows for up to two ultrasonic sensors, one pressure sensor and one temperature sensor to be integrated and routed through the RotoLevel LT device. This data is then routed to our RotoHub device and transmitted via 3G/4G to our Data Portal.

